

BALL VALVE Type 21,21α



Features

- Equipped with top flange, allowing for easy change to automatic valve
- Comes with bottom stand to facilitate mounting on racks and panels.
- Double O-RING on the stem improves durability and sealing property.

■Multi Functional Handle

Removing the handle and placing the Raised lugs into the carrier allow for Easy disassembly of the valve.

The handle has other colors. (white, blue, yellow)(Option)



Basic specifications

- Valve Type : Ball Valve Type 21, 21α
- Size : 10 mm — 100 mm (3/8 inch — 4 inch)
- Body Material : U-PVC (Conforming to ASTM D1784 Cell Classification 12454A)
C-PVC (Conforming to ASTM D1784 Cell Classification 23567-A)
PP (Conforming to ASTM D4101 Cell Classification PP0110B67272)
PVDF (Conforming to ASTM D3222 Cell Classification Type II)
- Seal Material / O-ring : EPDM, FKM etc.
- Connection / Flanged : JIS B2220 10K, DIN/EN1092-1 PN10/PN16, ANSI B16.5 CLASS150
Socket : JIS, DIN, ASTM D2466 SCH40
Threaded : Rc, Rp, NPT
Spigot : DIN

Body Material	FLUID TEMPERATURE °C [°F]	Max. working pressure (Normal temperature) MPa {psi }	Connection method			
			Flanged	Socket	Threaded	Spigot
PVC	0 ~ 60 { 30~140 }	1.6 { 230 }	○	○	○	○
C-PVC	0 ~ 90 { 30~195 }	1.6 { 230 }	○	○	○	-
PP	-20 ~ 80 { -5~176 }	1.0 { 150 }	○	○	○	○
PVDF	-20 ~ 100 { -5~210 }	1.6 { 230 }	○	○	○	○

Note::

- (1) The ball-type valves have dead spaces for structural reasons. Note that volatile liquids, such as hydrogen peroxide (H₂O₂) and sodium hypochlorite (NaClO), vaporize in those dead spaces, which may cause abnormal pressure increase in the valve. (When the internal pressure abnormally increases due to vaporization, the gas will be compressive fluid. If the valve breaks in this state, it will be very dangerous, causing explosion and scattering of fragments.)
- (2) The maximum working pressure is the value including the water hammer pressure. Be careful that the maximum working pressure is not exceeded during use.

* Concerning the allowable pressure for each temperature and material, see the technical documents at the next page of this sheet.

Certificate / Approval / Directive

PED, ABS, NSF/ANSI61

“For details of applicable products, please consult us.”

Working pressure vs. Temperature

[JIS]

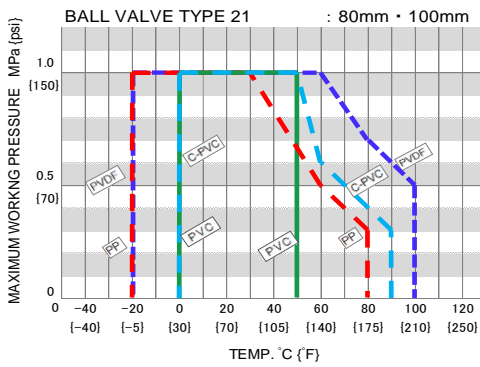
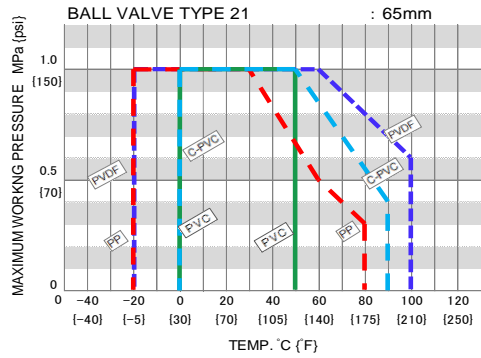
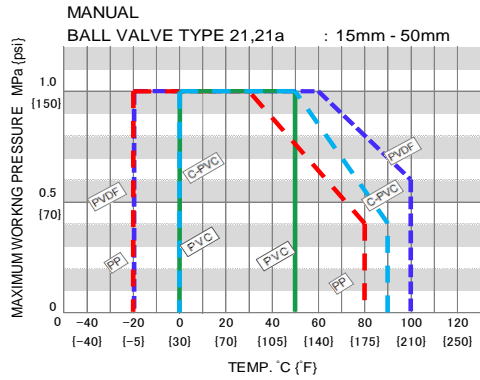

[DIN, ANSI]

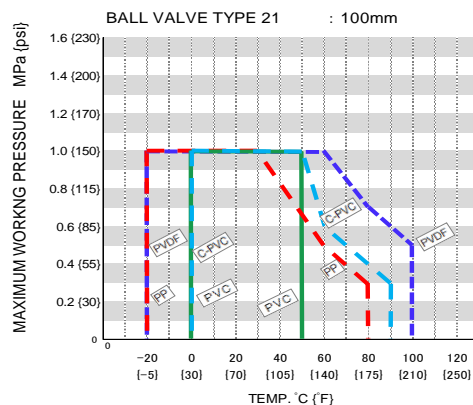
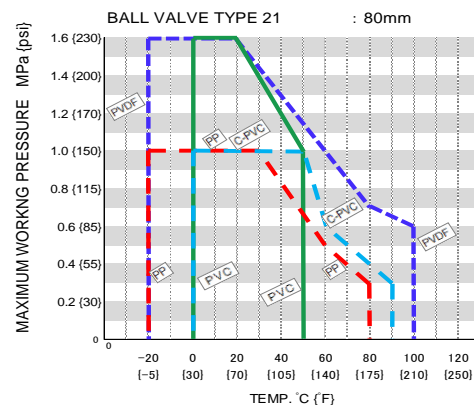
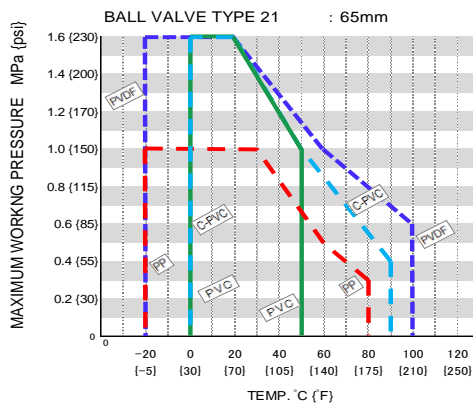
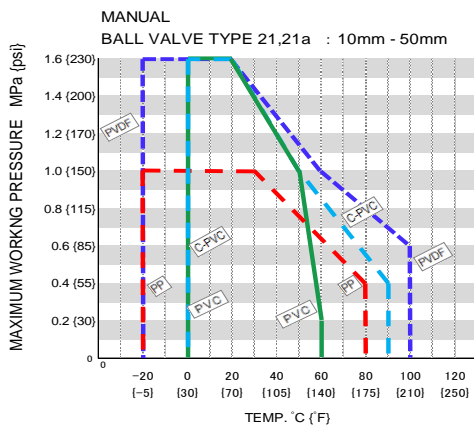

Product dimension

FLANGED

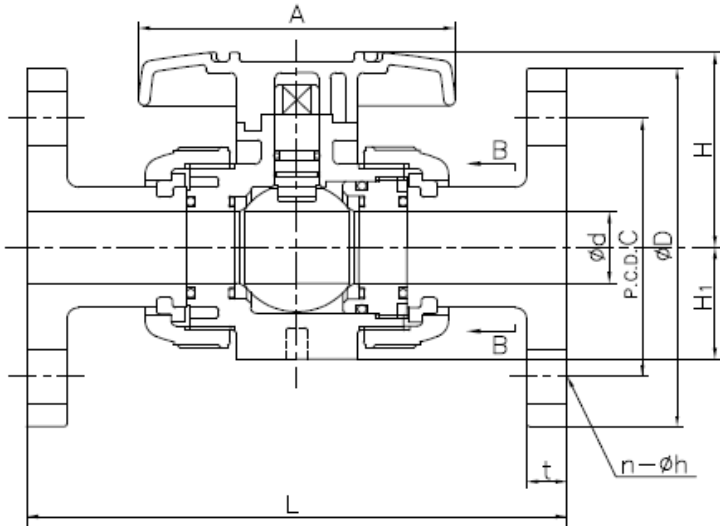

(DETAILS OF STEM)

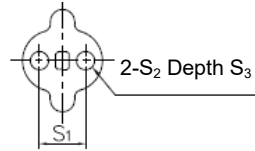
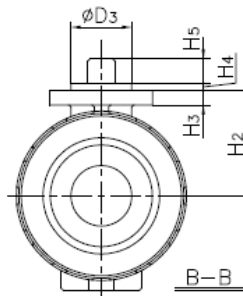
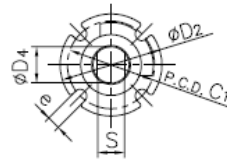

(DETAILS OF ENSAT FITTING MOUNTING HOLE)

SOCKET

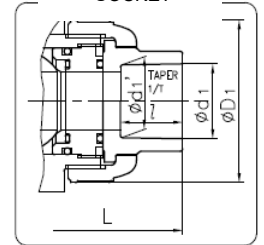

THREADED

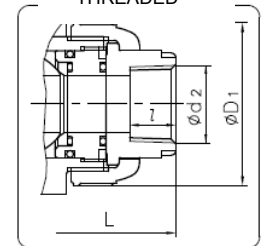

■ JIS, DIN (Unit: mm)

mm	d	d'	D ₁	D ₂	D ₃	D ₄	C ₁	H	H ₁	H ₂	H ₃	H ₄	H ₅	A	S	S ₁	S ₂	S ₃	e
10	13	-	46	-	-	-	-	43.5	-	-	-	-	-	80	-	-	-	-	-
15	15	-	48	42	25	13.5	36	51.5	29	30	6	3	8	92	10.5	19	7.3	11	5.5
20	20	-	60	42	25	15	36	59.5	35	36.5	6	3	10	100	11	19	7.3	11	5.5
25	25	-	70	42	25	15	36	68	39	43.5	6	3	10	110	11	19	7.3	11	5.5
32	32	-	82	48	30	19	42	80.5	47	52.5	8	3	10	121	15	30	9	15	5.5
40	40	-	100	57	35	23	50	89	55	61	10	3	12	131	18	30	9	15	6.5
50	51	-	126	57	35	23	50	102.5	66	72.5	10	3	12	159	18	30	9	15	6.5
65	65	58	133	81	55	30	70	126	72	85	13	3	16	200	24	48	9	6	9
80	78	68.5	152	81	55	30	70	140	85	94	13	3	19	240	24	55	11	7	9
100	100	90	210	116	70	40	102	178	110	126	16	3	23	300	34	65	11	8	11

■ JIS, (Unit: mm)

mm	JIS																								
	FLANGED												SOCKET						THREADED						
	JIS 5K				JIS 10K				L				PVC, C-PVC			PP			d ₂	ℓ	L				
	D	C	n	h	D	C	n	h	PVC C-PVC	PP	PVDF	t	d ₁	ℓ	1/T	L	d ₁	d ₁ '			ℓ	L	PVC C-PVC	PP	PVDF
15	80	60	4	12	95	70	4	15	143	143	143	12	22.11	20	1/34	109	21.2	20.2	20	108	Rc1/2	15	102	100	100
20	85	65	4	12	100	75	4	15	172	172	172	14	26.13	24	1/34	128	26.2	25.2	23	126	Rc3/4	17	120	119	119
25	95	75	4	12	125	90	4	19	187	187	187	14	32.16	27	1/34	145	33.0	32.0	25	141	Rc1	20	131	130	130
32	115	90	4	15	135	100	4	19	190	190	190	16	38.19	30	1/34	162	-	-	-	-	Rc1 1/4	22	150	146	146
40	120	95	4	15	140	105	4	19	212	212	212	16	48.21	37	1/37	189	47.0	46.0	28	171	Rc1 1/2	25	163	160	160
50	130	105	4	15	155	120	4	19	234	234	234	16	60.25	42	1/37	220	59.0	58.0	28	192	Rc2	28	197	194	194
65	155	130	4	15	175	140	4	19	261	257	256	18	76.60	61	1/48	273	75.00	73.00	35	219	Rc2 1/2	32	215	213	212
80	180	145	4	19	185	150	8	19	306	305	302	18	89.60	64	1/49	316	88.0	86.00	35	257	Rc3	35	265	264	261
100	200	165	8	19	210	175	8	19	374	374	369	18	114.70	84	1/56	419	113.00	111.00	45	341	Rc4	45	362	362	357

DATASHEET

■ DIN (Unit: mm)

		DIN																												
mm	FLANGED DIN PN10/PN16								SOCKET								THREADED				SPIGOT									
	D	C	n	h	L			t	PVC, C-PVC			PP, PVDF					d ₂	ℓ	L			PVC			PP, PVDF					
					PVC C-PVC	PP	PVDF		d ₁	ℓ	L	d ₁	d ₁ '	ℓ	L				d ₁	d ₁ '	ℓ	d ₁	d ₁ '	ℓ	t ₁		L			
															PP	PVDF									PP	PVDF	PP	PVDF	PP	PVDF
10	90	60	4	14	120	119	119	12	16	14	99	15.5	15.4	13	96	96	Rp3/8	15	99	98	98	16	13	16	—	—	—	—	114	114
15	95	65	4	14	130	130	130	12	20	16	102	19.5	19.3	14.5	99	99	Rp1/2	15	102	100	100	20	15	18.5	20	18.5	2.5	1.9	124	124
20	105	75	4	14	150	150	150	14	25	19	119	24.5	24.3	16	113	113	Rp3/4	17	120	119	119	25	20	24	25	22	2.7	1.9	144	144
25	115	85	4	14	160	160	160	14	32	22	131	31.5	31.3	18	123	123	Rp1	20	131	130	130	32	25	24.5	32	22.5	3.0	2.4	154	154
32	140	100	4	18	180	180	180	16	40	26	150	39.45	39.2	20.5	139	139	Rp1 1/4	22	150	146	146	40	31	28	40	26	3.7	2.4	174	174
40	150	110	4	18	200	200	200	16	50	31	164	49.45	49.2	23.5	149	149	Rp1 1/2	25	163	160	160	50	40	34	50	32	4.6	3.0	194	194
50	165	125	4	18	230	230	230	16	63	38	197	62.5	62.1	27.5	176	176	Rp2	28	197	194	194	63	51	38	63	36	5.8	3.0	224	224
65	185	145	4	18	290	288	287	18	75	44	233	74.25	73.95	31	205	204	Rp2 1/2	32	215	213	212	75	65	44	75	38	6.9	3.6	245	244
80	200	160	8	18	312	311	308	21	90	51	284	89.2	88.85	35.5	252	249	Rp3	35	265	264	261	90	80	51	90	38	8.2	4.3	296	293
100	220	180	8	18	352	352	347	18	110	61	351	109.05	108.65	41.5	312	307	Rp4	45	340	340	335	110	93.6	46	110	44.5	10.0	5.3	355	350

■ ANSI (Unit: inch)

inch	mm	d	d'	D ₁	D ₂	D ₃	D ₄	C ₁	H	H ₁	H ₂	H ₃	H ₄	H ₅	A	S	S ₁	S ₂	S ₃	e
1/2	15	0.59	—	1.89	1.65	0.98	0.53	1.42	2.03	1.14	1.18	0.24	0.12	0.31	3.62	0.41	0.75	0.29	0.43	0.22
3/4	20	0.79	—	2.36	1.65	0.98	0.59	1.42	2.34	1.38	1.44	0.24	0.12	0.39	3.94	0.43	0.75	0.29	0.43	0.22
1	25	0.98	—	2.76	1.65	0.98	0.59	1.42	2.68	1.54	1.71	0.24	0.12	0.39	4.33	0.43	0.75	0.29	0.43	0.22
1 1/4	32	1.26	—	3.23	1.89	1.18	0.75	1.65	3.17	1.85	2.07	0.31	0.12	0.39	4.76	0.59	1.18	0.35	0.59	0.22
1 1/2	40	1.57	—	3.94	2.24	1.39	0.91	1.97	3.50	2.17	2.40	0.39	0.12	0.47	5.16	0.71	1.18	0.35	0.59	0.26
2	50	2.01	—	4.96	2.24	1.38	0.91	1.97	4.04	2.60	2.85	0.39	0.12	0.47	6.26	0.71	1.18	0.35	0.59	0.26
2 1/2	65	2.56	2.28	5.24	3.19	2.17	1.18	2.76	4.96	2.83	3.35	0.51	0.12	0.63	7.87	0.94	1.89	0.35	0.24	0.35
3	80	3.07	2.70	5.98	3.19	2.17	1.18	2.76	5.51	3.35	3.70	0.51	0.12	0.75	9.45	0.94	2.17	0.43	0.28	0.35
4	100	3.94	3.54	6.27	4.57	2.76	1.57	4.02	7.01	4.33	4.96	0.63	0.12	0.91	11.81	1.34	2.56	0.43	0.31	0.43

		ANSI																								
inch	mm	FLANGED								SOCKET								THREADED								
		ANSI CLASS 150				L				t	PVC, C-PVC				PP, PVDF				d ₂	ℓ	L					
		D	C	n	h	PVC C-PVC	PP	PVDF	ASTM SCH40		ASTEM SCH80		d ₁	ℓ	L		PVC C-PVC	PP			PVDF					
									d ₁		d ₁ '	ℓ			L	d ₁						d ₁ '	ℓ	L		
1/2	15	3.50	2.38	4	0.62	5.63	5.63	5.63	0.47	—	—	—	—	0.848	0.836	0.875	4.45	0.86	0.87	4.41	4.41	1/2 - 14 NPT	0.59	4.02	7.02	4.02
3/4	20	3.88	2.75	4	0.62	6.77	6.77	6.77	0.55	—	—	—	—	1.058	1.046	1.000	5.08	1.03	1.00	5.00	5.00	3/4 - 14 NPT	0.67	4.72	4.72	4.72
1	25	4.25	3.12	4	0.62	7.36	7.36	7.36	0.55	—	—	—	—	1.325	1.310	1.125	5.71	1.30	1.13	5.63	5.63	1-1 1/2 NPT	0.79	5.16	5.16	5.16
1 1/4	32	4.62	3.50	4	0.62	7.48	7.48	7.48	0.63	—	—	—	—	1.670	1.655	1.250	6.46	1.65	1.25	6.30	6.30	1 1/4-11 1/2 NPT	0.87	5.91	5.91	5.91
1 1/2	40	5.00	3.88	4	0.62	8.35	8.35	8.35	0.63	—	—	—	—	1.912	1.894	1.375	7.24	1.89	1.37	7.05	7.05	1 1/2-11 1/2 NPT	0.98	6.42	6.42	6.42
2	50	6.00	4.75	4	0.75	9.21	9.21	9.21	0.63	—	—	—	—	2.387	2.369	1.500	8.23	2.36	1.50	8.03	8.03	2-11 1/2 NPT	1.10	7.76	7.76	7.76
2 1/2	65	7.00	5.50	4	0.75	10.20	10.12	10.08	0.71	—	—	—	—	2.889	2.868	1.750	9.45	2.88	1.752	9.37	9.33	2 1/2-8NPT	1.26	8.48	8.39	8.35
3	80	7.50	6.00	4	0.75	12.05	12.01	11.89	0.71	—	—	—	—	3.516	3.492	1.875	11.14	3.48	1.874	11.10	10.98	3-8 NPT	1.38	10.43	10.39	10.28
4	100	9.00	7.50	8	0.75	14.72	14.72	14.53	0.71	4.518	4.491	2.000	1.386	—	—	—	—	4.48	2.252	14.37	14.13	4-8 NPT	1.77	14.25	14.25	14.06

Parts list

15 – 50 mm

[FLANGED]

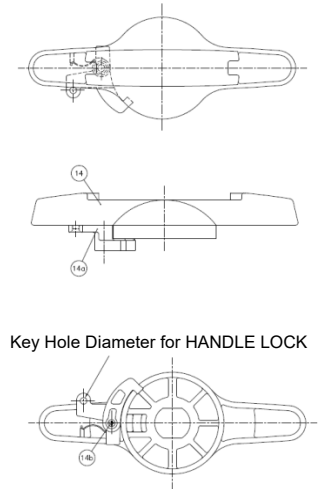
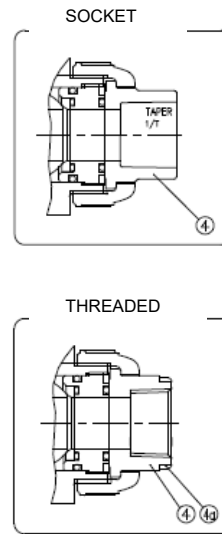
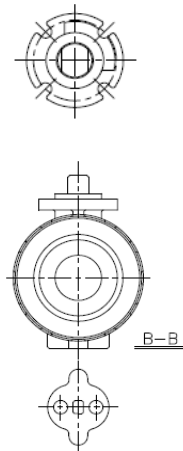
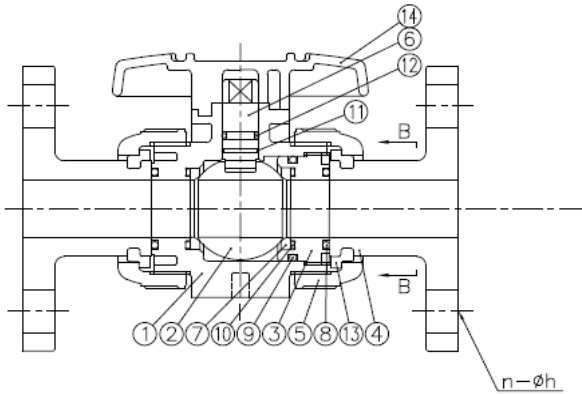

PART NO./NAME	QTY	MATERIAL	PART NO./NAME	QTY	MATERIAL	PART NO./NAME	QTY	MATERIAL
1 BODY	1	PVC, C-PVC, PP, PVDF	8 O-RING (A)	2	EPDM, FKM, Others ()	14 HANDLE	1	ABS
2 BALL	1	PVC, C-PVC, PP, PVDF	9 O-RING (B)	1		14a ROCKING LEVER	1	PPG
3 CARRIER	2	PVC, C-PVC, PP, PVDF	10 O-RING (C)	2		14b TAPPING SCREW (C)	1	STAINLESS STEEL
4 END CONNECTOR	2	PVC, C-PVC, PP, PVDF	11 O-RING (D)	2		4a RING	2	STAINLESS STEEL
5 UNION NUT	2	PVC, C-PVC, PP, PPG, PVDF	12 O-RING (E)	1		Used for C-PVC BODY Threaded End : 15 to 25mm		
6 STEM	1	PVC, C-PVC, PP, PVDF	13 STOP RING	2	Used for Flanged End			
7 SEAT	2	PTFE						

65 – 100 mm

[FLANGED]

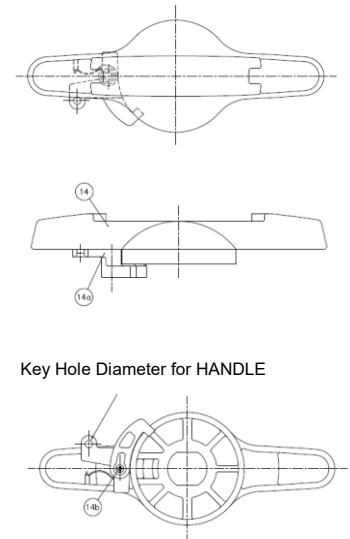
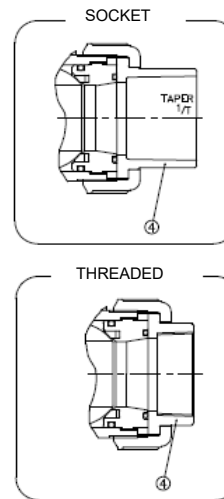
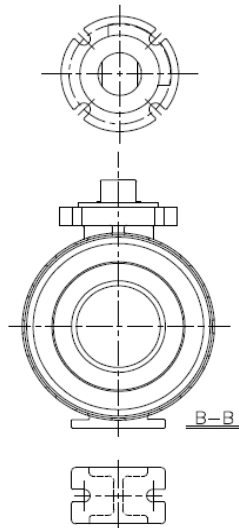
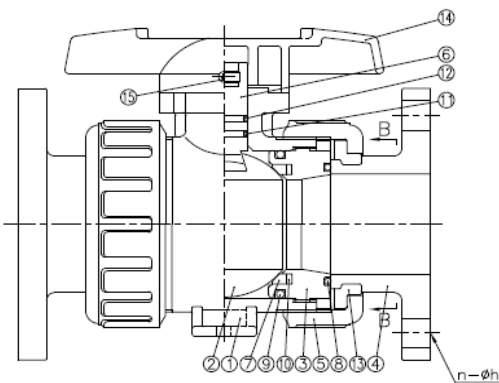

PART NO./NAME	QTY	MATERIAL	PART NO./NAME	QTY	MATERIAL	PART NO./NAME	QTY	MATERIAL
1 BODY	1	PVC, C-PVC, PP, PVDF	7 SEAT	2	PTFE	13 STOP RING	2	PVDF
2 BALL	1	PVC, C-PVC, PP, PVDF	8 O-RING (A)	2	EPDM, FKM, Others ()	Used for flanged end		
3 CARRIER	1	PVC, C-PVC, PP, PVDF	9 O-RING (B)	1		14 HANDLE	1	ABS
4 END CONNECTOR	2	PVC, C-PVC, PP, PVDF	10 CUSHION	2		14a ROCKING LEVER	1	PPG
5 UNION NUT	2	PVC, C-PVC, PP, PPG, PVDF	11 O-RING (D)	1		14b TAPPING SCREW (C)	1	STAINLESS STEEL
6 STEM	1	PVC, C-PVC, PP, PVDF	12 O-RING (E)	1		15 TAPPING SCREW (A)	1	STAINLESS STEEL

Cv value for each opening degree

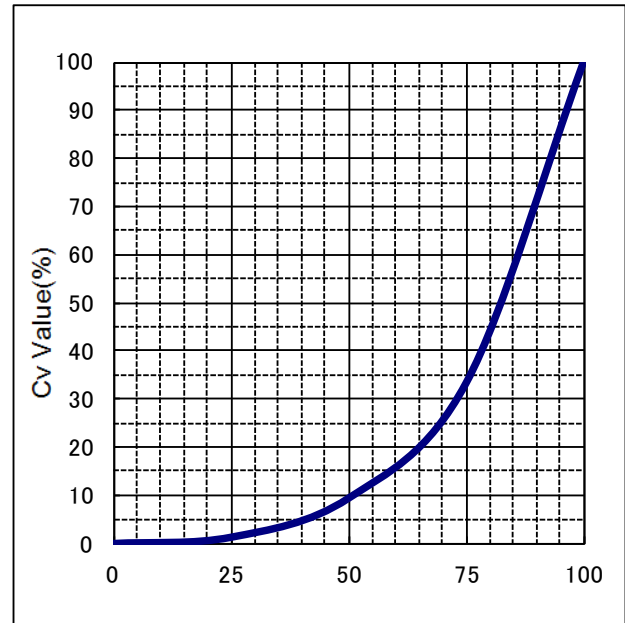

FULL-OPEN Cv VALUE

mm	10	15	20	25	32	40	50	65	80	100
inch	3/8	1/2	3/4	1	1 1/4	1 1/2	2	2 1/2	3	4
FULL-OPEN Cv VALUE	7.7	14	29	47	72	155	190	365	410	680

The values shown are reference values, not guaranteed values.

Operating torque

UNIT : N · m

mm	inch	Operation torque (O→S) N · m
10	3/8	1.6
15	1/2	2.0
20	3/4	2.5
25	1	3.2
32	1 1/4	5.6
40	1 1/2	8.0
50	2	10
65	2 1/2	22
80	3	40
100	4	80

ENSAT (METAL INSERT) MOUNTING PROCEDURE

BALL VALVE TYPE 21, 21α

15mm - 50mm



At the bottom of the valve body, a "holed bottom stand" is provided which can be easily secured to a rack or panel only by inserting an Ensat.

★ Install the metal insert (Ensat) in the procedure below.

<When using the special tool>

Attach the Ensat at the end of special tool with the splitting groove facing downward.

While ensuring that the center is aligned with the prepared hole from the front, back, right and left, screw the Ensat in to the predetermined depth.

After the Ensat is screwed in completely, hold the nut with a spanner while turning the upper portion of the tool in the reverse direction. The tool will be freely movable and come out.

<When using a bolt and nut>

Screw the Ensat in a double nut fashion. After the Ensat is screwed in, hold the bolt and loosen the nut. The bolt will be freely movable and can be removed.

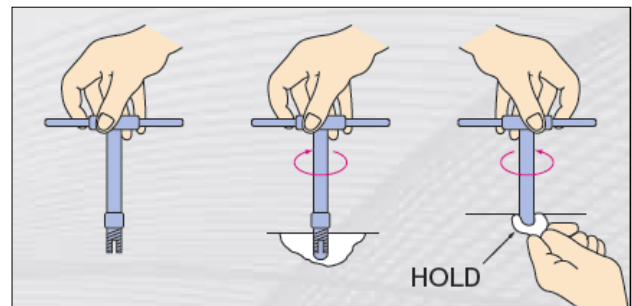
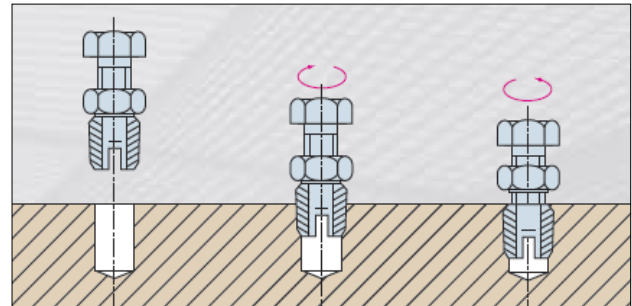

When the Ensat is manually screwed in, the center alignment between the Ensat and the prepared hole is particularly important. Check that the Ensat is inserted perpendicular to the prepared hole while screwing it in. If it is tilted, do not turn the tool backward, but just put the Ensat in its correct position. Note that, when nearly half of the Ensat is once inserted, its position can no longer be corrected.

NOTE For details of how to handle the Ensat mounting special tool, see to instruction manual provided by the Ensat manufacturer. (K.K.V.CORPORATION)

Product weight

TYPE 21, TYPE 21α

UNIT : kg

mm	inch	FLANGED				THREADED				SOCKET, SPIGOT			
		PVC	C-PVC	PP	PVDF	PVC	C-PVC	PP	PVDF	PVC	C-PVC	PP	PVDF
10	3/8	0.3	0.4	0.2	0.4	0.2	0.2	0.1	0.2	0.2	0.2	0.1	0.2
15	1/2	0.4	0.4	0.3	0.5	0.2	0.2	0.2	0.2	0.2	0.2	0.2	0.2
20	3/4	0.6	0.7	0.5	0.7	0.3	0.3	0.3	0.4	0.3	0.3	0.3	0.3
25	1	0.8	0.9	0.7	1.0	0.4	0.5	0.4	0.5	0.4	0.5	0.4	0.5
32	1 1/4	1.2	1.3	0.9	1.5	0.7	0.7	0.6	0.8	0.6	0.7	0.5	0.7
40	1 1/2	1.7	1.8	1.2	2.0	1.1	1.2	0.7	1.3	1.0	1.0	0.8	1.2
50	2	2.5	2.7	1.8	3.7	1.8	2.0	1.2	2.2	1.7	1.8	1.2	2.0
65	2 1/2	3.3	3.5	2.4	4.0	2.3	2.5	1.7	2.8	2.4	2.6	1.7	2.8
80	3	4.9	5.5	3.4	5.7	3.7	4.0	2.5	4.5	3.8	4.1	2.4	4.4
100	4	10.5	10.6	7.0	12.1	8.8	9.9	6.0	11.3	9.2	9.9	6.0	10.8

Spigot: PVC, PP, PVDF only.

- Note:
- (1) PP and PVDF socket types are weld type. Note, however, that JIS PP 32-mm socket type is not produced.
 - (2) PVDF socket type compatible with the JIS standard is not available.
 - (3) A handle set with a lock mechanism (for malfunction prevention) is available as an option.

Product model code list

ACTUATION	TYPE	OPERATING SYSTEM	BODY MATERIAL	SEAL MATERIAL	CONNECTION	STANDARD	SIZE
V	**	LV	*	*	*	***	***
:	:	:	:	:	:	:	:
V MANUAL VALVE	21 TYPE 21 2A TYPE 21A	LV LEVER TYPE	U PVC C C-PVC P PP F PVDF	E EPDM V FKM	S SOCKET N THREADED P SPIGOT F FLANGED	J SOCKET D DIN A ANSI 1 10K 5 5K	010 10mm 5 100 100mm

Installation, Operation and Maintenance Manual

"For details of Installation, Operation and Maintenance, please contact our nearest distribution agent or sales office.